



ista | OVERVIEW

This document is an overview only. To access the full procedure, please visit the ISTA store at www.ista.org.

ISTA 6 Series
Member
Performance
Test
PROJECT*

VERSION
DATE
Last
TECHNICAL
Change:
APRIL 2018

Last
EDITORIAL
Change:
APRIL 2018

For complete
listing of
Procedure
Changes and
Version Dates
go to
www.ista.org

ISTA, Distributing Confidence, Worldwide™

ISTA 6 Series tests are advanced tests and are designed to:

- Challenge the capability of the package and product to withstand transport hazards, **but**
- Utilize general simulation of actual transport hazards, **and**
- Do not necessarily comply with carrier packaging regulations.

When properly executed, ISTA procedures will provide tangible benefits of:

- Product to market time reduction
- Confidence in product launch
- Reduction in damages and product loss
- Balanced distribution costs
- Customer satisfaction contributing to increased market share

There are three sections to this Procedure: Overview, Testing and Reporting

- **Overview** provides general knowledge required before testing **and**
- **Testing** presents the specific instructions to do laboratory testing **and**
- **Reporting** indicates what data shall be recorded to submit a test report to ISTA.

Two systems of weights and measures are presented in ISTA test procedures: SI (Metric) or English system (Inch-Pound). Metric units are shown first followed by the Inch-Pound units in parentheses; there are exceptions in some tables (when shown separately).

Familiarity with the following units and symbols used in this document is required:

For measuring	Metric units and symbols	English units and symbols
Weight	kilograms (kg) or grams (gm)	pounds (lb)
Distance	meters (m) or millimeters (mm)	feet (ft) or inches (in)
Volume	Cubic centimeters (cm ³)	Cubic inches (in ³)
Density	kilograms per cubic meter (kg/m ³)	pounds per cubic inch (lb/in ³)
Temperature	Centigrade (°C)	Fahrenheit (°F)
Absolute Pressure	Kilopascal (kPa)	Pounds per square inch (psi)

- Either system may be used as the unit of measure (standard units), **but**
- The standard units chosen shall be used consistently throughout the procedure.
- Units are converted to two significant figures **and**
- Not exact equivalents.

VERY IMPORTANT:

The entire document shall be read and understood before proceeding with a test.

* Notes Regarding ISTA “Projects” and “Procedures”

- ISTA® 6-Amazon.com-Over Boxing is currently an ISTA “Project”, first released in August 2016. New ISTA test protocols are given the designation “Project” during their implementation phase. After a minimum one-year period and required evaluation, a “Project” will either be adopted as an established “Procedure”, revised and kept as a “Project” for another period of time, or be dropped. Therefore, a “Project” is potentially subject to greater and more frequent revision than a “Procedure”.
- ISTA members may use either Procedures or Projects for package certification.
- Comments regarding this Project and its use are encouraged and welcome. Please contact ista@ista.org.

Preface

Test Project 6-Amazon.com-Over Boxing is a general simulation test for e-Commerce fulfillment. In comparison to items ready to ship in its own packaging (Test Project 6-Amazon.com- SIOC), this kind of e-Commerce fulfillment comprises an individual retail packaged-product being placed into a master shipping container (Over Box) either by itself with the addition of dunnage (air pillows or Kraft paper) or with multiple individual retail packaged-products with dunnage for shipment from Amazon.com to an end consumer through a parcel delivery system which could include modes of air, rail, or truck. This test challenges the packaging and/or products, whether primary package or transport package, ability to withstand the general damage-producing motions, forces, conditions, and sequences of this environment.

- **e-Commerce Fulfillment** shipment shall be defined as any packaged-product configuration where: The retail individual packaged-product is not intended to ship in its own shipping container
- Single or multiple retail packaged-products are placed into a corrugated shipping container (“over-box”) with dunnage for shipment to an end customer from an e-retailer or distribution center
- **Single item or Multiple item order. Examples below:**

SINGLE



MULTI

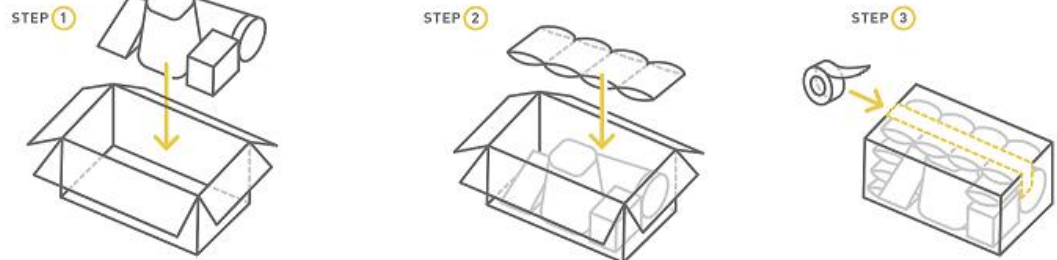

Definitions:

- **Dunnage** - loose materials used to support and protect product in a shipping container - for example- air pillows or Kraft paper.
- **Air Pillows** - inflatable void fill typically made of LDPE #4 or HDPE #2 plastics. Air pillows shall have dimensions of 8 in x 4 in (203 mm x 102 mm) and have a maximum thickness of 1.0 mil.
- **Fragile Products** – **Liquids** and other items that could easily break when dropped without having protective packaging; for example- glass, ceramics, porcelains, clay, electronics, etc. See below for **Liquids** definition.
- **Hazards Products** - Hazard products are reusable items to simulate other packaged products in a multiple shipment.
- **Kraft Paper** - paper dunnage used to fill void space and protect products within e-Commerce shipments.
- **Liquids** - or semi-liquids or solids that can become liquid at high temperatures (above 70 degrees Fahrenheit) which can leak from a primary vessel within e-Commerce shipments.
- **Multiple Product Shipment** - more than one product ordered online and has been consolidated into one shipping container.
- **Non-Fragile Products** - items that are not considered Fragile or Liquids- see above for **Fragile Product** and **Liquids** definition.
- **Over-Boxing** - placement of a shipping container/carton around a single product or multiple products for intent to ship via single parcel delivery.

Continued on next page

Continued from previous page

Definitions (continued):

- **Single Product Shipment** - single product order online that cannot be shipped as-is without the need of being placed into a shipping container/carton.
- **Tertiary Carton** - shipping container/carton made of corrugated board.
- **Test Specimen** - item being tested and evaluated- for example- bottle of shampoo.

General Considerations:

- Testing can be used to evaluate the protective performance of a packaged-product related to vibrations, shocks and other stresses normally encountered during handling and transportation in a parcel delivery system.
- Test levels are based on general data and may not represent any specific distribution system.
- The package and product are considered together and not separately.
- Some conditions of transit, such as moisture, pressure or unusual handling may not be covered.

Other ISTA Procedures may be appropriate for different conditions or to meet different objectives.

Refer to *Guidelines for Selecting and Using ISTA Procedures and Projects* for additional information.

NOTE:

Hazardous Material (Dangerous Goods) packaging that passes this test procedure may not meet international, national or other regulatory requirements for the transport of Hazardous Materials (Dangerous Goods). **This test is not a substitute** for United Nations and/or any other required test standards for the transport of Hazardous Materials (Dangerous Goods), but may be used as an additional test in conjunction with them.

Scope

Test Project 6-Amazon.com-Over Boxing covers testing of individual packaged-products weighing 70 pounds (32 kilograms) or less when prepared for e-Commerce fulfillment by being over-boxed and shipped via a parcel delivery carrier.

Product Damage Tolerance and Package Degradation Allowance

The shipper and Amazon.com shall determine the following prior to testing:

- what constitutes damage to the product (test specimen) **and**
- what damage tolerance level is allowable, if any, **and**
- the correct methodology to determine product condition at the conclusion of the test **and**
- the acceptable package condition at the conclusion of the test.

Acceptance Criteria:

Not meeting the criteria below will result in a **Failed** test (Test Specimen Only):

- Product is fully functional in its intended use
- No leaks
- Any Tamper Evident application is not compromised- seal integrity is intact
- Any secondary packaging that is considered part of the product is free from serious damage/indentations/scratching

The Hazard products, dunnage, or tertiary packaging are not to be considered in the acceptance criteria.

For additional information on this determination process refer to *Guidelines for Selecting and Using ISTA Procedures and Projects*.

OVERVIEW OF PROJECT 6-Amazon.com

Samples should be an untested actual package and product, but if one or both are not available, the substitutes shall be as identical as possible to actual items.

Samples

The table below provides the Total Samples Required for this test based upon Test Specimen Weight and Product Type (Non-Fragile or Fragile). Fragile items include such things as glass, ceramics, porcelains, clay, electronics, etc. as well as Liquids. See Glossary of Definitions at the end of this procedure.

Shipment Configuration	Test Specimen Weight			
	Less Than 15 lbs (6.80 kg)		15 lbs (6.80 kg) or Greater	
	Non-Fragile	Fragile	Non-Fragile	Fragile
Single Item	1	2	1	5
Multiple Item	1	3	0	0
Total Samples Required	2	5	1	5

Refer to *Guidelines for Selecting and Using ISTA Procedures and Projects* for additional information on statistical sampling.

Documentation

In order to ensure testing in perfect condition, products and packages shipped to an ISTA Certified Laboratory for testing shall be:

- Adequately over-packaged for shipment **or**
- Repackaged in new packaging at the laboratory.
- It is important to thoroughly document the configuration, materials, and construction of the tested product and package. Significant variations in performance can sometimes be caused by seemingly insignificant differences. Photo documentation is required to supplement detailed written descriptions and should include pre-test, during testing and post test images.

Basis Weights of Corrugated Board

When the outer package is a corrugated box, it is strongly recommended that the basis weights of the papers/paperboards used to make the box be determined and documented. If the nominal basis weights change, even if the board is rated for the same performance, a retest is appropriate.

Basis Weight

Refer to *Guidelines for Selecting and Using ISTA Procedures and Projects* for additional information on documentation and basis weight determination.

Test Sequence

Sequence Number	Test Category	Test Type	Test Level	For ISTA Certification
1	Atmospheric Preconditioning TEST BLOCK 1	Temperature and Humidity	Ambient	Required
2	Atmospheric Conditioning TEST BLOCK 1	Controlled Temperature and Humidity	Temperature and Humidity chosen from chart	Optional
3	Shock TEST BLOCK 2	Drop	9 Drops	Required
4	Vibration TEST BLOCK 3	Random	Overall G _{rms} level of 0.53	Required
5	Shock TEST BLOCK 4	Drop	8 Drops	Required
6	Integrity TEST BLOCK 5	Leak Test	8 hours	Required for Liquids ONLY

Δ

EQUIPMENT REQUIRED FOR PROJECT 6-Amazon.com

Equipment
Required
Atmospheric
Conditioning

Atmospheric Conditioning:

- Humidity recorder complying with the apparatus section of ISO 2233 or ASTM D 4332.
- Temperature recorder complying with the apparatus section of ISO 2233 or ASTM D 4332.

Optional Atmospheric Conditioning

- Chamber and Control apparatus complying with the apparatus section of ISO 2233 or ASTM D 4332.

Equipment
Required
Shock

All Protocols	
Type of Shock Test	Drop Test
Type of Equipment	Free-fall drop tester
In compliance with the apparatus section of...	ISO 2248 or ASTM D 5276
Additional Required Equipment	<p>Hazard block: The block shall be made of hardwood or metal. The height shall be 20 to 25 mm (0.75 to 1.0 in) and the width 150 mm (6.0 in). The length shall be at least 200 mm (8.0 in) longer than the second shortest package dimension of the length, width and height. The long top edges of the block shall be rounded to a radius equal to the height of the block ± 2.0 mm (0.0625 in).</p>

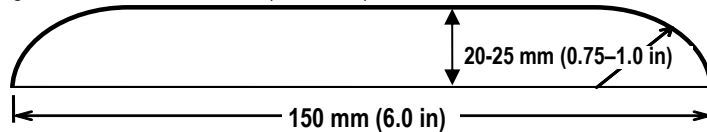
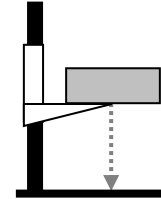

Equipment
Required
Vibration

Random Vibration Test:

- Random Vibration Test System complying with the apparatus section of ISO 13355 or ASTM D 4728.

Equipment
Required
Additional

SINGLE & MULTI-PRODUCT Shipment – Over Box

- A corrugated Over Box is needed to simulate a typical pack out.
- See Before You Begin – Pack Out for details on Over Box material construction.
- 2 in (50.8 mm) wide poly tape is used to seal an Over Box.

SINGLE & MULTI-PRODUCT Shipment – Dunnage

- Air Pillow dunnage is used to simulate a typical pack out.
- See Before You Begin Testing – Pack Out and Preface - Definitions for details on Air Pillow dunnage material construction.

MULTI-PRODUCT Shipment – Hazard Products

Constructing hazard products for multiple item shipment

- Hazard products are reusable items to simulate other packaged products in a multiple shipment.
- Construct hazard products by adding steel shot, sand, or other dense flowable material a plastic bag to reach intended desired weight. Seal the bag and place into an RSC/RET carton (or like) and brace the weight with paper dunnage to prevent the weight from sliding within each hazard carton and eliminate concentrated load.
- Minimum board to be used in making the Hazard Products is 32 ECT C-Flute.
- If the Hazard Products are reused, insure that the carton is not heavily worn (rounded edges, fatigued corrugate). Periodic replacement will be needed for consistent testing.

Δ

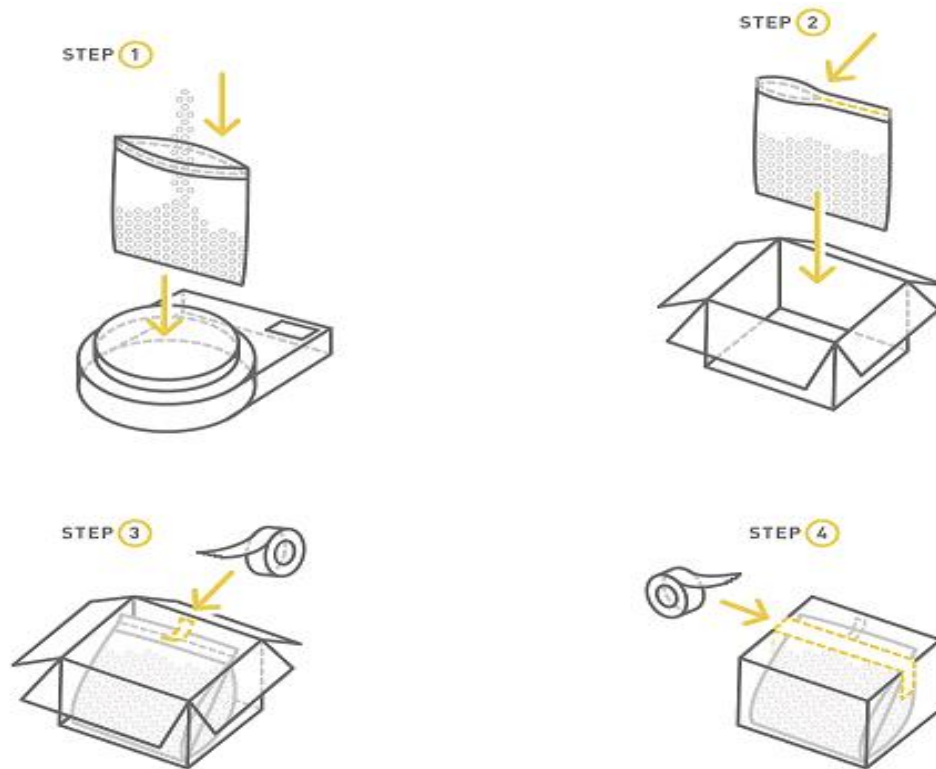

Continued on next page

EQUIPMENT REQUIRED FOR PROJECT 6-Amazon.com

Continued from previous page

MULTI-PRODUCT Shipment – Hazard Products

Constructing hazard products for multiple item shipment - CONTINUED

The following describes the weights and sizes of each Hazard Product for **Multiple Product shipments**:

- The following describes the name and sizes of each hazard product. It is suggested to make multiple quantities of each size for testing purposes.
- Hazard Product Packages can be constructed from a fiberboard box of any style.
- The contents within the Hazard Product Package shall be **steel shot**, sand, or other dense flowable material.
- “**Custom**” Hazard Products shall be constructed with vary dimensions, allowing for the Hazard Product(s) to fit into the designated Over Box. The *Custom* Hazard Product must contain the specified *Approximate Weight* from the table below.

Name	Approximate Size LxWxH		Approximate Weight*	
	Millimeters (mm)	Inches (in)	Kilograms (kg)	Pounds (lb)
A	102 x 102 x 25	4.0 x 4.0 x 1.0	0.23	0.5
B	76 x 76 x 76	3.0 x 3.0 x 3.0	0.45	1.0
C	76 x 76 x 76	3.0 x 3.0 x 3.0	0.68	1.5
D	102 x 76 x 76	4.0 x 3.0 x 3.0	1.0	2.0
E	152 x 102 x 102	6.0 x 4.0 x 4.0	1.13	2.5
F	102 x 102 x 102	4.0 x 4.0 x 4.0	1.36	3.0
G	102 x 76 x 51	4.0 x 3.0 x 2.0	1.59	3.5
H	152 x 152 x 21	6.0 x 6.0 x 2.0	1.81	4.0
I	<i>Custom</i>	<i>Custom</i>	2.04	4.5
J	<i>Custom</i>	<i>Custom</i>	2.49	5.5

NOTE:

*A tolerance of ±3% is allowed for this specified Hazard Product weight.

SINGLE & MULTI-PRODUCT Shipment – Hazard Product & Over Box Selection

Determine the number of Hazard Products to place in the test box (Over Box) along with the TEST SPECIMEN

- The Over Box should be filled with the Test Specimen and dunnage material, to simulate a typical pack out.
- It is **not** acceptable to substitute hazard products with additional or multiple Test Specimen packages.
- The chart below outlines the number of items inside the Over Box, including the Test Specimen as well as the potential Over Box sizes utilized for this test.
- Over Boxes shall be constructed from C-Flute corrugated board.
- Over Boxes for Test Items weighing 15.0 lbs (6.80 kg) or greater shall be constructed with dimensions that are 2.0 in (50.8 mm) greater than the largest Test Specimen Length, Width & Height dimension.
- *Example:* If the Test Specimen has dimensions of (LxWxH) 30.0 in x 22.0 in x 12.0 in, then the Over Box should have dimensions of 32.0 in x 24.0 in x 14.0 in.

Continued on next page

Equipment
Required
Additional
Continued

Δ

Before You
Begin
Pack-out

Continued from previous page

Before You
Begin
Pack-out

Using the Tables Below:

- **Single Product Shipment:** An Over Box should be selected from the “Over Box” table below starting with the smallest carton then defaulting to the next sized carton until the Test Specimen fits within the Over Box. See Before You Begin Testing – Pack Out for instructions on how to place the Test Specimen in the Over Box.
- **Multi-Product Shipment:** Determine the number and type of hazard products from the “Hazard Products” table based upon the Test Specimen weight. Once the hazard products have been identified, an Over Box should be selected from the “Over Box” table below starting with the smallest carton then defaulting to the next sized carton until the Test Specimen & Hazard Products fit within the Over Box. See Before You Begin Testing – Pack Out for instructions on how to place the Test Specimen and Hazard Products in the Over Box.

NOTE: If the Test Specimen and Hazard Products do not fit in the smallest carton, default to the next sized carton until all the items fit.

HAZARD PRODUCTS			
Weight of Test Specimen	Hazard Name	Test Specimen	Number of Items Inside Shipment Over Box Including Test Specimen
0 to < 0.5 lbs (0 kg to <0.23 kg)	A,B,D	1	4
0.5 lbs to < 1.5 lbs (0.23 kg to < 0.68 kg)	A,C,D	1	4
1.5 to < 2.5 lbs (0.68 kg to < 1.13 kg)	B,C,D	1	4
2.5 lbs to < 3.0 lbs (1.13 kg to < 1.36 kg)	B,C,D	1	4
3.0 lbs to < 4.0 lbs (1.36 kg to < 1.81 kg)	B,D,D	1	4
4.0 lbs to < 5.0 lbs (1.81 kg to < 2.27 kg)	D,D,D	1	4
5.0 to < 6.0 lbs (2.27 kg to < 2.72 kg)	F,H	1	3
6.0 lbs to < 7.0 lbs (2.72 kg to < 3.18 kg)	F,G	1	3
7.0 lbs to < 8.0 lbs (3.18 kg to < 3.63 kg)	F,H	1	3
8.0 lbs to < 9.0 lbs (3.63 kg to < 4.08 kg)	E,H	1	3
9.0 to < 10.0 lbs (4.08 kg to < 4.54 kg)	J,H	1	3
10.0 lbs to < 11.5 lbs (4.54 kg to < 5.22 kg)	I,J	1	3
11.5 lbs to < 13.0 lbs (5.22 kg to < 5.90 kg)	J,G	1	3
13.0 lbs to < 15.0 lbs (5.90 kg to < 6.80 kg)	I,F	1	3
15.0 lbs to ≤ 70.0 lbs (6.80 kg to ≤ 32.00 kg)	None	1	1

OVER BOX			
Internal Length (in)	Internal Width (in)	Internal Height (in)	Style and ECT Rating
10.0	7.0	3.0	RSC/29
13.0	9.0	4.0	RSC/32
16.0	12.0	3.0	RSC/32
14.0	10.0	5.0	RSC/32
14.0	8.0	7.0	RSC/32
19.0	12.0	4.0	RSC/32
16.0	12.0	6.0	RSC/32
18.0	9.0	8.5	RSC/32
19.0	13.0	6.0	RSC/32
14.0	12.0	10.0	RSC/32
18.0	14.0	8.0	RSC/32
22.0	18.0	12.0	RSC/44
22.0	18.0	12.0	RSC/44
22.0	18.0	12.0	RSC/44
Product + 2.0	Product + 2.0	Product + 2.0	RSC/32