

ISTA 6 Series Member Performance Test PROJECT\*

ISTA, Distributing Confidence, Worldwide™

ISTA® 6-Series Member Performance Tests are protocols created by ISTA members to suit their own particular purposes and applications. This 6-AMAZON.COM test was developed by ISTA in cooperation with Amazon.com, and is designed as a General Simulation protocol. General Simulation tests

- J Challenge the capability of the package and product to withstand transport hazards, but
- J Utilize general simulation of actual transport hazards, and
- J Do not necessarily comply with carrier packaging regulations.

VERSION DATE

When properly executed, ISTA procedures will provide tangible benefits of:

- J Product to market time reduction
- J Confidence in product launch
- J Reduction in damage and product loss
- J Balanced distribution costs
- J Customer satisfaction contributing to increased market share

Last TECHNICAL Change: May 2016

There are three sections to this procedure: Overview, Testing, and Reporting

- J Overview provides general knowledge required before testing and
- J Testing presents the specific instructions to do laboratory testing and
- J Reporting indicates what data shall be recorded to submit a test report.

Last EDITORIAL Change: May 2016

Two systems of weights and measures are presented in ISTA test procedures: English system (Inch-Pound) or SI (Metric). Inch-Pound units are shown first followed by the Metric units in parentheses; there may be exceptions in some tables (when shown separately).

Familiarity with the following units and symbols used in this document is required:

For measuring	English units and symbols	Metric units and symbols
Weight	pounds (lb)	kilograms (kg) or grams (gm)
Force	pounds force (lbf)	newtons (N)
Distance	feet (ft) or inches (in)	meters (m) or millimeters (mm)
Velocity	inches per second (in/sec)	meters per second (m/sec) or millimeters per second (mm/sec)
Volume	cubic inches (in <sup>3</sup> )	cubic centimeters (cm <sup>3</sup> ) or cubic meters (m <sup>3</sup> )
Density	pounds per cubic inch (lb/in <sup>3</sup> )	kilograms per cubic meter (kg/m <sup>3</sup> )
Temperature	Fahrenheit (°F)	Celsius (°C)

For complete listing of Procedure Changes and Version Dates go to [www.ista.org](http://www.ista.org)

- J Either system may be used as the unit of measure, but
- J The units chosen shall be used consistently throughout the procedure.
- J Units are typically converted to two significant figures and
- J Not exact equivalents.

## VERY IMPORTANT:

**The entire document shall be read and understood before proceeding with a test.**

\* Notes Regarding ISTA "Projects" and "Procedures"

- J ISTA® 6-AMAZON.COM is currently an ISTA "Project", first released in October 2014. New ISTA test protocols are given the designation "Project" during their implementation phase. After a minimum one-year period and required evaluation, a "Project" will either be adopted as an established "Procedure", revised and kept as a "Project" for another period of time, or be dropped. Therefore, a "Project" is potentially subject to greater and more frequent revision than a "Procedure".
- J ISTA members may use either Procedures or Projects for package certification.
- J Comments regarding this Project and its use are encouraged and welcome. Please contact [ista@ista.org](mailto:ista@ista.org).

## Preface

Project 6-AMAZON.COM is a general simulation test for “Ships In Own Container” (SIOC) packaged-products shipped through Amazon’s distribution system to final customer destinations. This testing protocol has been developed by combining data from previous studies of transportation environments, relevant testing protocols, Amazon Fulfillment Center environment visual observations, and customer feedback.

This test is for packaged-products shipped by Vendors to Amazon.com Fulfillment Centers and delivered to final customer destinations via Parcel or Less-Than-Truckload (LTL) outbound shipment methods. It challenges the capability of both package and product to withstand transport hazards normally encountered during handling and transportation. Amazon.com Vendors with items intended to utilize Ships In Own Container (SIOC) are encouraged to use this test to understand the protective performance of their packaging.

Project 6-AMAZON.COM has been created by Amazon.com with help from industry experts in both the packaging and transportation industries. This test is currently in the Project phase (pilot stage) and will be improved upon if/where needed using feedback from industry experts and users of the test. It is requested that you share feedback and other data from any testing conducted using this test including number of tests conducted, failure/success rate, types of failures, test performance compared to real world comparison, and any other helpful data points. Please share your feedback with [package-testing@amazon.com](mailto:package-testing@amazon.com) Amazon.com will share this data with ISTA in an effort to improve the effectiveness of the test protocol.

Project 6-AMAZON.COM is appropriate for six (6) different types of packaged-products designated Types A through F below. The different types are a combination of three (3) packaged-product criteria: Amazon.com Outbound Shipment Method, Amazon.com Fulfillment Center Handling Method, and Packaged-Product Weight. See Definitions below for an explanation of packaged-product types and other terms used in this document.

## Packaged-Product Test Types

- J Type A:
  - o Shipment Method: Parcel Delivery of Individual Packaged-Products
  - o Handling Method: Standard Handling Method
  - o Weight: Less than 50 lb (23 kg)
- J Type B:
  - o Shipment Method: Parcel Delivery of Individual Packaged-Products
  - o Handling Method: Standard Handling Method
  - o Weight: 50 lb (23 kg) to Less than 100 lb (43 kg)
- J Type C:
  - o Shipment Method: Parcel Delivery of Individual Packaged-Products
  - o Handling Method: Standard Handling Method
  - o Weight: 100 lb (43 kg) or Greater
- J Type D:
  - o Shipment Method: Less-Than-Truckload (LTL) Delivery of Individual Packaged-Products
  - o Handling Method: Standard Handling Method
  - o Weight: Less than 100 lb (43 kg)
- J Type E:
  - o Shipment Method: Less-Than-Truckload (LTL) Delivery of Individual Packaged-Products
  - o Handling Method: Standard Handling Method
  - o Weight: 100 lb (43 kg) or Greater
- J Type F:
  - o Shipment Method: Less-Than-Truckload (LTL) Delivery of Individual Packaged-Products
  - o Handling Method: Pallet Handling Method
  - o Weight: N/A

## Packaged-Product Criteria

- J Amazon.com Outbound Shipment Method:
  - o Parcel Delivery of Individual Packaged-Products
  - o Less-Than-Truckload (LTL) Delivery of Individual Packaged-Products
    - Packaged-Product Weight Greater than 150 lb or
    - Any Packaged-Product Dimension Greater than 108 inches or
    - Packaged-Product Girth Greater than 165 inches (Girth = Length + 2 \* (Width + Height)) or
    - Palletized Packaged-Product or
    - Special Delivery Requirement by Amazon

- J Amazon.com Fulfillment Center (FC) Handling Method:
  - o Standard Handling Method (Floor Loaded) – Individual packaged-products that are received at Amazon.com Fulfillment Center with no pallet or with multiple packaged products on a single pallet and are intended to ship to the end consumer without a pallet.
  - o Pallet Handling Method - Individual packaged-products that are received at Amazon.com Fulfillment Center on its own individual pallet and is intended to ship to the end consumer on a pallet.
- J Weight of Packaged-Product:
  - o Less than 50 lb (23 kg)
  - o 50 lb (23 kg) to Less than 100 lb (43 kg)
  - o 100 lb (43 kg) or Greater

## Definitions

- J Parcel Delivery.
    - o Any individual packaged-product shipped by Amazon.com to the consumer via a Parcel delivery system such as UPS, FedEx, etc. (including elongated and flat packaged-product)
  - J Less than Truckload (LTL) Standard Packaged-Product
    - o Any packaged-product shipped by Amazon.com to the consumer via an LTL delivery system (including elongated and flat packaged-product) that is not palletized or skidded
  - J Less than Truckload (LTL) Palletized Packaged-Product
    - o Any packaged-product shipped by Amazon.com to the consumer via an LTL delivery system (including elongated and flat packaged-product) that is individually palletized or skidded
  - J Standard and Custom Pallet. A standard pallet is a design which is in wide industry use, with published specifications, quality, and applications, used within those specifications and in a typical application. Standard pallets have information, provided by their manufacturers or distributors, available on the internet. A custom pallet is one designed for a specific product or narrow range of products, and with its design and performance characteristics not widely known or published.
  - J Elongated Packaged-Product
    - o A packaged-product where the longest dimension is 36 in (910 mm) or greater and
    - o both of the other dimensions are each 20 percent or less of the longest dimension
  - J Flat Packaged-Product
    - o A packaged-product where the shortest dimension is 8 in (200 mm) or less and
    - o the next longest dimension is four (4) or more times larger than the shortest dimension, and
    - o the volume is 800 in<sup>3</sup> (13,000 cm<sup>3</sup>) or greater
- NOTE: If a packaged-product is both Elongated and Flat in accordance with the above definitions, it should be tested as Elongated.
- J Non-Rigid Containers are defined as having one or more of the following characteristics:
    - o the outer package may offer insufficient protection from concentrated low-level impacts or
    - o the design has large unsupported spans of outer packaging material or
    - o the outer package utilizes a stretch- or shrink-wrap design, a thin-flute or light grade corrugated board, a paper wrap or similar lightweight material only, etc. or
    - o the outer package wall is in direct contact with the product

## General

- J Testing can be used to evaluate the protective performance of a packaged-product related to vibrations, shocks and other stresses normally encountered during handling and transportation in the Amazon.com distribution system.
- J The package and product are considered together and not separately.
- J Some conditions of transit, such as moisture, pressure, or unusual handling may not be covered.

Other ISTA Procedures or Projects may be appropriate for different conditions or to meet different objectives.

Refer to Guidelines for Selecting and Using ISTA Test Procedures and Projects for additional information.

## NOTE:

Hazardous Material (Dangerous Goods) packaging that passes this test procedure may not meet international, national or other regulatory requirements for the transport of Hazardous Materials (Dangerous Goods). This test is not a substitute for United Nations and/or any other required test standards for the transport of Hazardous Materials (Dangerous Goods), but may be used as an additional test in conjunction with them.

## Scope

Project 6-AMAZON.COM covers the testing of packaged-products prepared for shipment via Amazon.com's Ships In Own Container (SIOC) distribution system to North America destinations. In this system, packaged-products are typically shipped from the manufacturer or producer to an Amazon.com fulfillment center, and then to the Consumer. Various types of handling may occur in the fulfillment centers, including manual, fork lift, clamp truck, etc.

Product Damage  
Tolerance and  
Package  
Degradation  
Allowance

The shipper, manufacturer, Amazon.com and/or other stakeholders shall determine the following prior to testing, to permit the determination of pass or fail at the conclusion of the tests:

- J what constitutes damage to the product and
- J what damage tolerance level is allowable, if any, and
- J the correct methodology to determine product condition at the conclusion of the test and
- J the acceptable package condition at the conclusion of the test.

For additional information on these determinations refer to Guidelines for Selecting and Using ISTA Test Procedures and Projects.

Additional  
Information,  
IMPORTANT

The shipper, manufacturer, Amazon.com or other stakeholders shall also provide information regarding the initial shipment configuration, approved container loading diagram, details of shipment and configurations within the distribution system, typical atmospheric conditions, etc. as required to determine proper testing parameters.

## Samples

Both products and packages should be as close as possible to actual production items. Pre-production prototypes such as hand-made samples, CAD-generated one-of-a-kind or short run samples, etc. are usually not sufficiently representative of production items to yield meaningful test results. It may be appropriate to conduct preliminary tests of a product and package early in the development cycle, but final official testing should be performed with actual production items.

For fragile items, five samples are required for the Type A test procedure. Fragile items are defined as items that easily break or could leak during the distribution process. This includes any item containing:

- J Glass / Ceramic / Porcelain / Clay
- J Liquids / Semi-liquids / Solids that can become liquid at high temperatures (above 70 degrees Fahrenheit)

When multiple identical samples are tested, all samples must pass all tests.

For non-fragile items, one sample is required for this test procedure. If the sample is a palletized or a unitized load and this is the intended configuration for shipment to the end consumer, then this is constituted a single packaged-product.

To permit an adequate determination of representative performance of the packaged-product, ISTA:

- J Requires the test procedure, with the required number of samples, to be performed one time, but
- J Recommends performing the entire test procedure five or more times using new samples for each test.

Refer to Guidelines for Selecting and Using ISTA Test Procedures and Projects for additional information.

NOTE: In order to ensure testing in perfect condition, products and packages shipped to an ISTA Certified Laboratory for testing shall be:

- J Adequately over-packaged for shipment or
- J Repackaged in new packaging at the laboratory.

NOTE: Any pallet or skid used in this procedure should be of a type and condition which is typical of what is in actual field use for the packaged-product being tested.

NOTE: It is important to thoroughly document the configuration, materials, and construction of the tested product and package. Significant variations in performance can sometimes be caused by seemingly insignificant differences. Photo documentation is strongly recommended to supplement detailed written descriptions.

## OVERVIEW OF PROJECT 6-AMAZON.COM-SIOC

The tests shall be performed on each test sample in the sequence indicated in the following tables:

Test Sequence  
Type A

## Type A - Parcel Delivery of Individual Packaged-Products Less Than 50 lb (23 kg)

Parcel Delivery  
of Individual  
Packaged-  
Products  
Less Than  
50 lb (23 kg)

Sequence Number	Test Category	Test Type	Test Level	Remarks
1	Atmospheric Preconditioning TEST BLOCK 1	Temperature and Humidity	Lab ambient, 12 hours	Required
2	Atmospheric Conditioning TEST BLOCK 1	Controlled Temperature and Humidity	Temperature and humidity chosen from chart	Optional
3	Shock TEST BLOCK 2	Free-Fall Drop	9 Drops - height varies with packaged-product weight	Required
4	Vibration TEST BLOCK 12	Random With and Without Top Load	Overall Grms levels of 0.53 and 0.46	Required
5	Shock TEST BLOCK 15	Free-Fall Drop	8 Drops - height varies with packaged-product weight. Includes drop on hazard	Required
6	Shock TEST BLOCK 21	Rotational Edge Drop	9 in (230 mm)	Required for Elongated and Flat Packages
7	Shock TEST BLOCK 22	Full Rotational Flat Drop	Varies with packaged-product dimensions	Required for Elongated and Flat Packages
8	Shock TEST BLOCK 23	Bridge Impact	Hazard Box dropped 16 in (400 mm)	Required for Elongated Packages Only
9	Shock TEST BLOCK 24	Concentrated Edge Impact	Hazard Box dropped 16 in (400 mm)	Required for Flat Packages Only
10	Integrity TEST BLOCK 25	Leak Test	8 hours	Required for Liquids ONLY

For fragile items, five samples are required for the Type A test procedure. Fragile items are defined as items that easily break or could leak during the distribution process. This includes any item containing:

- J Glass / Ceramic / Porcelain / Clay
- J Liquids / Semi-liquids / Solids that can become liquid at high temperatures (above 70 degrees Fahrenheit)

When multiple identical samples are tested, all samples must pass all tests.

## OVERVIEW OF PROJECT 6-AMAZON.COM-SIOC

Type B - Parcel Delivery of Individual Packaged-Products 50 lb (23 kg) to Less Than 100 lb (43 kg)

Test Sequence  
Type BParcel Delivery  
of Individual  
Packaged-  
Products  
50 lb (23 kg) to  
Less Than  
100 lb (43 kg)

Sequence Number	Test Category	Test Type	Test Level	Remarks
1	Atmospheric Preconditioning TEST BLOCK 1	Temperature and Humidity	Lab ambient, 12 hours	Required
2	Atmospheric Conditioning TEST BLOCK 1	Controlled Temperature and Humidity	Temperature and humidity chosen from table	Optional
3	Shock TEST BLOCK 2	Free-Fall Drop	9 Drops - height varies with packaged-product weight	Required
4	Shock TEST BLOCK 3	Tip/Tip Over	Use a 22 degree tip angle	Required for packages 48 in. (1.2 m) tall and any one base dimension < ½ the height; or for packages 30 in. (760 mm) tall and with a center of gravity vertical location > ½ the package height
5	Compression, Vertical TEST BLOCK 9	Test in the intended shipping orientation or most stable orientation	Calculated from formula Maintain force for 1 hour	Required Machine, or weights & load spreader
6	Compression, Horizontal TEST BLOCK 10	Clamping Simulation	Calculated from formula Clamp in multiple orientations as directed	Required For any of the 2 axes with a width dimension 24 in (610mm) and < 75 in (1905 mm)
7	Vibration TEST BLOCK 12	Random With and Without Top Load	Overall Grms levels of 0.53 and 0.46	Required
8	Shock TEST BLOCK 15	Free-Fall Drop	8 Drops - height varies with packaged-product weight. Includes drop on hazard	Required
9	Shock TEST BLOCK 21	Rotational Edge Drop	9 in (230 mm)	Required for Elongated and Flat Packages
10	Shock TEST BLOCK 22	Full Rotational Flat Drop	Varies with packaged-product dimensions	Required for Elongated and Flat Packages
11	Shock TEST BLOCK 23	Bridge Impact	Hazard Box dropped 16 in (400 mm)	Required for Elongated Packages Only
12	Shock TEST BLOCK 24	Concentrated Edge Impact	Hazard Box dropped 16 in (400 mm)	Required for Flat Packages Only
13	Integrity TEST BLOCK 25	Leak Test	8 hours	Required for Liquids ONLY

## OVERVIEW OF PROJECT 6-AMAZON.COM-SIOC

## Type C - Parcel Delivery of Individual Packaged-Products 100 lb (43 kg) or Greater

Note: Parcel Delivery has a weight limitation of 150 lb (70 kg)

Test Sequence  
Type CParcel Delivery  
of Individual  
Packaged-  
Products  
100 lb (43 kg)  
or Greater

Sequence Number	Test Category	Test Type	Test Level	Remarks
1	Atmospheric Preconditioning TEST BLOCK 1	Temperature and Humidity	Lab ambient, 12 hours	Required
2	Atmospheric Conditioning TEST BLOCK 1	Controlled Temperature and Humidity	Temperature and humidity chosen from chart	Optional
3	Shock TEST BLOCK 3	Tip/Tip Over	Use a 22 degree tip angle	Required for packages 48 in. (1.2 m) tall and any one base dimension < ½ the height; or for packages 30 in. (760 mm) tall and with a center of gravity vertical location > ½ the package height
4	Shock TEST BLOCK 5	Rotational FLAT Drop	9 in (230 mm)	Required
5	Shock TEST BLOCK 6	Rotational EDGE Drop	9 in (230 mm)	Required
6	Shock TEST BLOCK 8	Inclined or Horizontal Impact	48 in/sec (4 ft/sec) (1.2 m/sec) impact velocity or velocity change	Required
7	Compression, Vertical TEST BLOCK 9	Test in the intended shipping orientation or most stable orientation	Calculated from formula Maintain force for 1 hour	Required Machine, or weights & load spreader
8	Compression, Horizontal TEST BLOCK 10	Clamping Simulation	Calculated from formula Clamp in multiple orientations as directed	Required For any of the 2 axes with a width dimension 24 in (610mm) and < 75 in (1905 mm)
9	Vibration TEST BLOCK 12	Random With and Without Top Load	Overall Grms levels of 0.53 and 0.46	Required
10	Shock TEST BLOCK 20	Inclined or Horizontal Impact	48 in/sec (4 ft/sec) (1.2 m/sec) impact velocity or velocity change	Required
11	Shock TEST BLOCK 21	Rotational Edge Drop	9 in (230 mm)	Required for Elongated and Flat Packages
12	Shock TEST BLOCK 22	Full Rotational Flat Drop	Varies with packaged-product dimensions	Required for Elongated and Flat Packages
13	Shock TEST BLOCK 23	Bridge Impact	Hazard Box dropped 16 in (400 mm)	Required for Elongated Packages Only
14	Shock TEST BLOCK 24	Concentrated Edge Impact	Hazard Box dropped 16 in (400 mm)	Required for Flat Packages Only

## OVERVIEW OF PROJECT 6-AMAZON.COM-SIOC

## Type D - LTL Delivery of Individual Packaged-Products Less Than 100 lb (43 kg)

Test Sequence  
Type DLTL Delivery  
of Individual  
Packaged-  
Products  
Less Than  
100 lb (43 kg)

Sequence Number	Test Category	Test Type	Test Level	Remarks
1	Atmospheric Preconditioning TEST BLOCK 1	Temperature and Humidity	Lab ambient, 12 hours	Required
2	Atmospheric Conditioning TEST BLOCK 1	Controlled Temperature and Humidity	Temperature and humidity chosen from table	Optional
3	Shock TEST BLOCK 3	Tip/Tip Over	Use a 22 degree tip angle	Required for packages 48 in. (1.2 m) tall and any one base dimension < ½ the height; or for packages 30 in. (760 mm) tall and with a center of gravity vertical location > ½ the package height
4	Shock TEST BLOCK 4	Free-Fall Drop	6 drops – 18 in (460 mm) max	Required
5	Compression, Vertical TEST BLOCK 9	Test in the intended shipping orientation or most stable orientation	Calculated from formula Maintain force for 1 hour	Required Machine, or weights and load spreader
6	Compression, Horizontal TEST BLOCK 10	Clamping Simulation	Calculated from formula Clamp in multiple orientations as directed	Required For any of the 2 axes with a width dimension 24 in (610mm) and < 75 in (1905 mm)
7	Vertical Vibration TEST BLOCK 13	Random With Top Load	Overall Grms level of 0.54	Required
8	Shock TEST BLOCK 16	Free-Fall Drop	6 drops – 32 in (810 mm) max	Required
9	Shock TEST BLOCK 22	Full Rotational Flat Drop	Varies with packaged-product dimensions	Required for Elongated and Flat Packages
10	Shock TEST BLOCK 23	Bridge Impact	Hazard Box dropped 16 in (400 mm)	Required for Elongated Packages Only
11	Shock TEST BLOCK 24	Concentrated Edge Impact	Hazard Box dropped 16 in (400 mm)	Required for Flat Packages Only



## OVERVIEW OF PROJECT 6-AMAZON.COM-SIOC

## Type E - LTL Delivery of Individual Packaged-Products 100 lb (43 kg) or Greater

Test Sequence  
Type ELTL Delivery  
of Individual  
Packaged-  
Products  
100 lb (43 kg)  
or Greater

Sequence Number	Test Category	Test Type	Test Level	Remarks
1	Atmospheric Preconditioning TEST BLOCK 1	Temperature and Humidity	Lab ambient, 12 hours	Required
2	Atmospheric Conditioning TEST BLOCK 1	Controlled Temperature and Humidity	Temperature and humidity chosen from table	Optional
3	Shock TEST BLOCK 3	Tip/Tip Over	Use a 22 degree tip angle	Required for packages 48 in. (1.2 m) tall and any one base dimension < ½ the height; or for packages 30 in. (760 mm) tall and with a center of gravity vertical location > ½ the package height
4	Shock TEST BLOCK 5	Rotational FLAT Drop	9 in (230 mm)	Required
5	Shock TEST BLOCK 6	Rotational EDGE Drop	9 in (230 mm)	Required
6	Shock TEST BLOCK 8	Inclined or Horizontal Impact	48 in/sec (4 ft/sec) (1.2 m/sec) impact velocity or velocity change	Required
7	Compression, Vertical TEST BLOCK 9	Test in the intended shipping orientation or most stable orientation	Calculated from formula Maintain force for 1 hour	Required Machine, or weights and load spreader
8	Compression, Horizontal TEST BLOCK 10	Clamping Simulation	Calculated from formula Clamp in multiple orientations as directed	Required For any of the 2 axes with a width dimension 24 in (610mm) and < 75 in (1905 mm)
9	Vertical Vibration TEST BLOCK 13	Random With Top Load	Overall Grms level of 0.54	Required
10	Shock TEST BLOCK 20	Inclined or Horizontal Impact	48 in/sec (4 ft/sec) (1.2 m/sec) impacts or 3 in. (76 mm) drops	Required
11	Shock TEST BLOCK 23	Bridge Impact	Hazard Box dropped 16 in (400 mm)	Required for Elongated Packages Only
12	Shock TEST BLOCK 24	Concentrated Edge Impact	Hazard Box dropped 16 in (400 mm)	Required for Flat Packages Only

## OVERVIEW OF PROJECT 6-AMAZON.COM-SIOC

## Type F - LTL Delivery of Individual Palletized Packaged-Products

Test Sequence  
Type FLTL Delivery  
of Individual  
Palletized  
Packaged-  
Products

Sequence Number	Test Category	Test Type	Test Level	Remarks
1	Atmospheric Preconditioning TEST BLOCK 1	Temperature and Humidity	Lab ambient, 12 hours	Required
2	Atmospheric Conditioning TEST BLOCK 1	Controlled Temperature and Humidity	Temperature and humidity chosen from chart	Optional
3	Shock TEST BLOCK 3	Tip/Tip Over	Use a 22 degree tip angle	Required for packages 48 in. (1.2 m) tall and any one base dimension < ½ the height; or for packages 30 in. (760 mm) tall and with a center of gravity vertical location > ½ the package height
4	Shock TEST BLOCK 5	Rotational FLAT Drop	9 in (230 mm)	Required
5	Shock TEST BLOCK 6	Rotational EDGE Drop	9 in (230 mm)	Required
6	Shock TEST BLOCK 7	Rotational CORNER Drop	9 in (230 mm)	Required
7	Shock TEST BLOCK 8	Inclined or Horizontal Impact	48 in/sec (4 ft/sec) (1.2 m/sec) impact velocity or velocity change	Required
8	Compression, Vertical TEST BLOCK 9	Top-to-Bottom Pallet on top	Calculated from formula	Required Machine or weights and load spreader
9	Shock TEST BLOCK 11	Fork Lift Simulation	Flat Push and Rotate tests, Elevated Push and Pull tests	Required
10	Vertical Vibration TEST BLOCK 14	Random With Top Load	Overall Grms level of 0.54	Required
11	Shock TEST BLOCK 17	Rotational FLAT Drop	9 in (230 mm)	Required
12	Shock TEST BLOCK 18	Rotational EDGE Drop	9 in (230 mm)	Required
13	Shock TEST BLOCK 19	Rotational CORNER Drop	9 in (230 mm)	Required
14	Shock TEST BLOCK 20	Inclined or Horizontal Impact	48 in/sec (4 ft/sec) (1.2 m/sec) impacts or 3 in. (76 mm) drops	Required
15	Shock TEST BLOCK 24	Concentrated Edge Impact	Hazard box dropped 16 in (410 mm)	Required for Flat Packages Only

# EQUIPMENT REQUIRED FOR PROJECT 6-AMAZON.COM-SIOC

Equipment  
Required  
Atmospheric  
Conditioning

Atmospheric Pre-Conditioning and Conditioning:

- ) Humidity recorder complying with of the apparatus section of ASTM D 4332 or ISO 2233.
- ) Temperature recorder complying with the apparatus section of ASTM D 4332 or ISO 2233.

Controlled Temperature and Humidity:

- ) Chamber and Control apparatus complying with the apparatus section of ASTM D 4332 or ISO 2233.

Equipment  
Required  
Shock

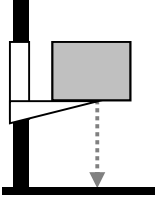
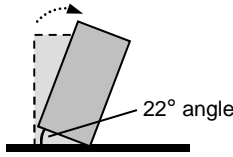
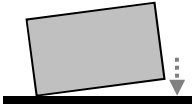
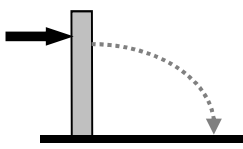
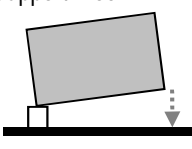
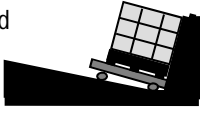
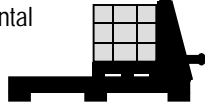
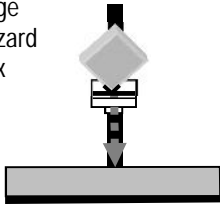
Type of Shock Test	Type of Equipment	Equipment Requirements	Additional Required Equipment
Free-Fall Drop Tests	Free-fall drop tester 	Compliance with the apparatus sections of ASTM D 5276 or ISO 2248.	
Tip/Tipover Tests	 22° angle	ASTM D 6179 or ISO 2876	
Rotational Flat Drop Tests		Compliance with the apparatus sections of ASTM D 6179 or ISO 2876.	
Full Rotational Drops		ASTM D 6179 or ISO 2876	
Rotational Edge and Corner Drop Tests	Support Block 	Compliance with the apparatus sections of ASTM D 6179 or ISO 2876.	Support block 3.5 to 4.0 in (90 to 100 mm) in height and width and at least 8 in (200 mm) longer than the longest package dimension to be supported.
Inclined or Horizontal Impact Tests (Alternates)	Inclined   Horizontal 	Compliance with the apparatus sections of ASTM D 880 or ASTM D 4003 or ISO 2244.	
Concentrated Edge Impact Tests	Free-fall drop tester with edge hazard box 	Drop tester in compliance with the apparatus sections of ASTM D 5276 or ISO 2248.	Concentrated Edge Hazard Box 12 x 12 x 12 in (305 x 305 x 305 mm) wood box with a total weight of 9 lb (4.1 kg). Any required ballast weight should be dense flowable material in a bag or bags, held in place with suitable void fill. The impact edge of the box shall be covered with angle iron.

# EQUIPMENT REQUIRED FOR PROJECT 6-AMAZON.COM-SIOC

Equipment  
Required  
Shock  
(continued)

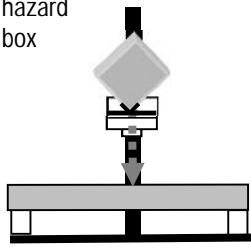
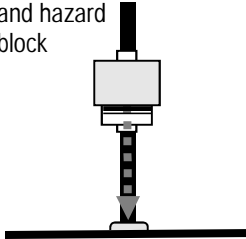
Bridge Impact Tests	Free-fall drop tester with edge hazard box 	Compliance with the apparatus section of ASTM D 5265, with the exception of the Hazard Box (Impactor).	Concentrated Edge Hazard Box and Support Blocks See above for description of the Concentrated Edge Hazard Box. Support blocks (2 ea) shall be 3.5 to 4.0 in (90 to 100 mm) in height and width and at least 8 in (200 mm) longer than the longest package dimension to be supported.
Drop Onto Hazard	Free-fall drop tester and hazard block 		Hazard Block See below.

### Hazard Block

The block shall be made of hardwood or metal. The height shall be to 1 in (20 to 25 mm) and the width shall be 6 in (150 mm). The length be at least 8 in (200 mm) longer than the longest package dimension will impact. The long top edges of the block shall be rounded to a radius equal to the height of the block.

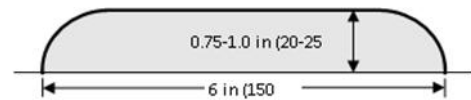

0.75  
shall  
which

Equipment  
Required  
Compression

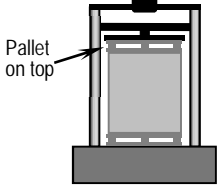
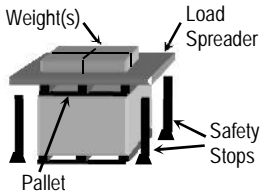
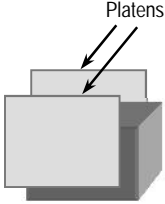
Type of Compression Test	Type of Equipment	Equipment Requirements	Additional Required Equipment
Vertical Compression (Top-to-Bottom)	Compression Test Machine 	Compliance with the apparatus section of ASTM D 642 - Fixed or Swivel Platen Acceptable.	If test item is shipped on a pallet (standard or custom), use an identical pallet on top.
Vertical Compression (Top-to-Bottom) (Alternate)	Weight(s) & Load Spreader 	The Load spreader must be larger than the top face of the test item, and shall be sufficiently rigid to apply a uniform compression force.	If test item is shipped on a pallet (standard or custom), use an identical pallet on top. Safety stops are recommended to support the load spreader and weight(s) to prevent damage or injury in the event of a rapid collapse of the test item.
Horizontal Compression (Clamping Simulation)	Clamp Tester 	Platens must be larger than the side dimensions of the test item, and with an opening sufficient to accommodate the test item. The desired compression must be achieved with minimum overshoot.	Controls must permit applying the required clamping force at a consistent rate and the ability to raise the test item a minimum of 12" (305 mm). Force measurement accuracy to within $\pm 5\%$ of the actual value, using accepted calibration means.

# EQUIPMENT REQUIRED FOR PROJECT 6-AMAZON.COM-SIOC

Equipment  
Required  
Vertical  
Vibration

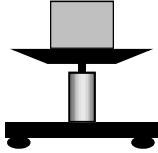
Type of Vibration Test	Type of Equipment	Equipment Requirements	Additional Required Equipment
Vertical Vibration	Random Vibration Test System 	Compliance with the apparatus section of ASTM D 4728 or ISO 13355	Means must be provided to maintain proper alignment of the test item and any top load apparatus, and to prevent the test item from moving off the vibration system's platform, without restricting vertical motion of the test item or apparatus.

Equipment  
Required  
Flat Push

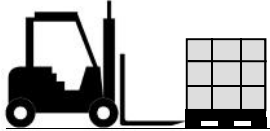
Type of Test	Type of Equipment	Equipment Requirements	Additional Required Equipment
Fork Lift Handling	Fork Lift Truck 	A fork lift truck of sufficient capacity to handle the test specimens and complying with the apparatus sections of ASTM D 6055 or ISO 10531.	

Equipment  
Required  
Additional

Vibration  
Top Load  
Apparatus for  
Type A, Type B  
and Type C  
Packaged-  
Products

The Top Load Apparatus required for the vibration testing of Type A, Type B and Type C packaged-products is detailed below

- J A fiberboard box, or other container, of sufficient strength and ability to hold a load spreader (such as a 3/4" piece of plywood or a plate of steel that is the same length and width as the inside dimensions of the load apparatus) and required weight for each axis and
- J The length and width dimensions of the Top-Load package or apparatus which will be applied to the test specimen shall each be a minimum of 50 mm (2 in) longer than each of the two dimensions of the test specimen's top face when positioned for testing [i.e., a minimum of 25 mm (1 in) overhang on each side] but
- J The length and width dimensions of the Top-Load package or apparatus may each be longer by a maximum of 150 mm (6 in) than each of the two dimensions of the test specimen's top face when positioned for testing [i.e., a maximum of 75 mm (3 in) overhang on each side] and
- J Some means of adding additional weight so that the Top-Load (TL) is distributed evenly over the entire inside face area of the Top-Load apparatus that will apply the Top-Load to the entire top face of the test specimen when it's positioned for testing and
- J Adequate void fill that shall securely hold the weight in place to prevent the weight from moving or bouncing within the top-load apparatus (it is also required to use stretch wrap around the test specimen and the top-load apparatus to prevent the top-load apparatus from bouncing on top of the test specimen) and
- J The top-load apparatus shall never be smaller than the test face; the calculated weight must cover the entire surface of the test face during the testing.

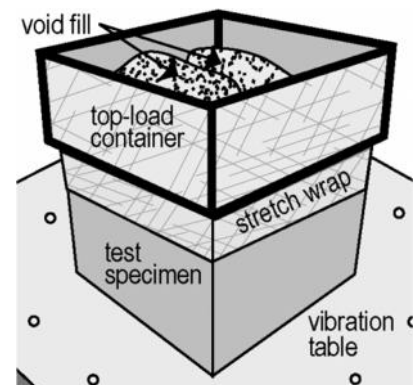

The Top Load Apparatus required for the vibration testing of Type D, Type E and Type F packaged-products is detailed below

Equipment  
Required  
Additional

Vibration  
Top Load  
Apparatus for  
Type D, Type E  
and Type F  
Packaged-  
Products

- J The Top Load Apparatus is described and shown below, and includes:
- o A sturdy fiberboard box or similar container with a height of 9 in (230 mm), and with a minimum 0.75 in (20 mm) thick plywood load spreader covering the entire inside bottom surface.
  - o Some means of adding additional weight as required so that the top load is distributed evenly over the entire inside bottom face area of the top load apparatus.
  - o Adequate void fill to securely hold the weight in place to prevent it from moving or bouncing within the top load apparatus.
  - o Bottom face dimensions (length and width) which are at least 2 in (50 mm) larger than the top face dimensions of the test item to which it is applied [for a minimum overhang of 1 in (25 mm) on each side], but must not be greater than 6 in (150 mm) larger than the top face dimensions of the test item [for a maximum of 3 in (76 mm) overhang on each side].
- J The Top Load Apparatus must be divided into 2 separate equal portions if one of the top face dimensions of the test item exceeds 18 in (460 mm), and into 4 separate equal portions if both of the top face dimensions of the test item exceed 18 in (460 mm).

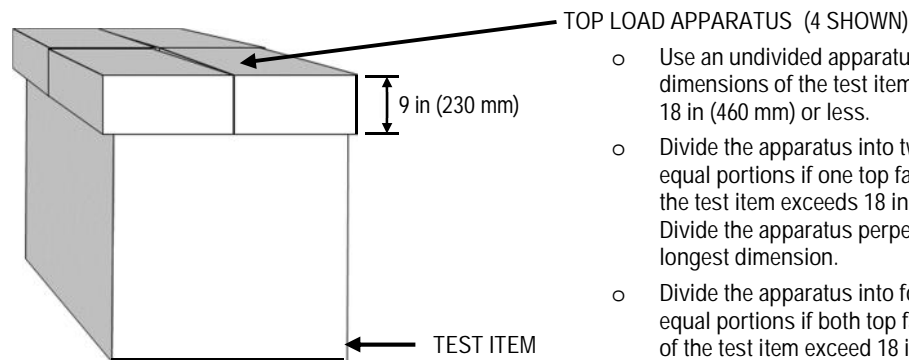

- o Use an undivided apparatus if both top face dimensions of the test item are 18 in (460 mm) or less.
- o Divide the apparatus into two separate equal portions if one top face dimension of the test item exceeds 18 in (460 mm). Divide the apparatus perpendicular to the longest dimension.
- o Divide the apparatus into four separate equal portions if both top face dimensions of the test item exceed 18 in (460 mm).

The Top Load is to simulate the effects of 6 lb/ft<sup>3</sup> (0.0035 lb/in<sup>3</sup>) (96 kg/m<sup>3</sup>) of assorted freight on top of a Floor-Loaded packaged-product in a truck-trailer or ocean container with an inside height of 108 in (2.7 m). This load density has been determined by empirical testing which resulted in correlation between damage in the test lab and damage in the field.

- J Means must be provided to maintain proper alignment of the Top Load Apparatus on the test item (column stack fixtures, stretch wrap around the test specimen and the top load apparatus, etc.), without restricting the vertical motion of the top load apparatus and the test specimen.